

NATIONAL AERONAUTICS AND SPACE ADMINISTRATION

Galaxy Evolution Explorer Launch

Press Kit
April 2003

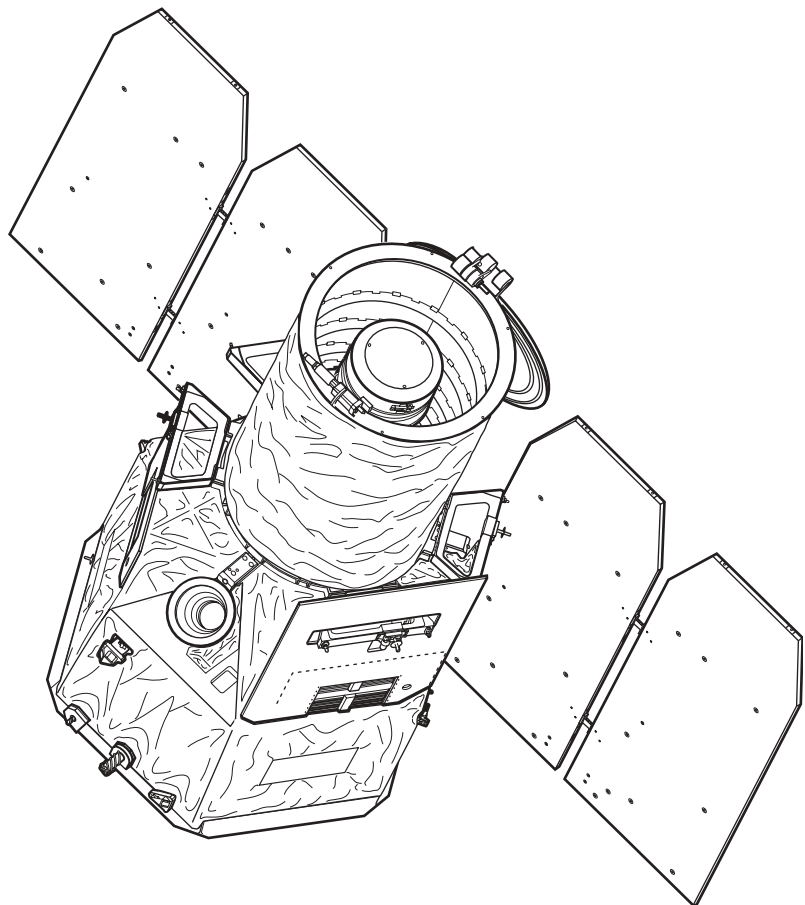

Media Contacts

Nancy Neal Headquarters Washington, D.C.	Policy/Program Management	202/358-2369 nneal@hq.nasa.gov
Jane Platt Jet Propulsion Laboratory, Pasadena, Calif.	Galaxy Evolution Explorer Mission	818/354-0880 jane.platt@jpl.nasa.gov
Mark Hess Goddard Space Flight Center, Greenbelt, Md.	Explorers Program	301/286-8982 mark.s.hess@nasa.gov
Robert Tindol California Institute of Technology, Pasadena, Calif.	Science Operations	626/395-3631 tindol@caltech.edu
George Diller Kennedy Space Center, Fla.	Launch	321/867-2468 george.diller-1@ksc.nasa.gov

Contents

General Release	3
Media Services Information	5
Quick Facts	6
Mission Overview	7
Why Study How Galaxies Form?	12
How Ultra is the Ultraviolet?	13
Science Objectives	14
Science Team	15
Spacecraft	18
The Telescope.....	23
NASA's Explorers Program	26
Program/Project Management	27

GENERAL RELEASE:

GALAXY EVOLUTION EXPLORER LOOKS BACK IN TIME

NASA's Galaxy Evolution Explorer will carry a telescope into Earth orbit that will observe a million galaxies across 10 billion years of cosmic history to help astronomers determine when the stars we see today had their origins.

Galaxy Evolution Explorer is set to launch no earlier than April 28, 2003, from Cape Canaveral Air Force Station, Fla. A Pegasus XL rocket, released by an L-1011 jet aircraft, will launch the satellite. The aircraft will climb to approximately 39,000 feet and release the launch vehicle and payload. The science mission will start after an initial month of in-orbit testing.

From its orbit high above Earth, the spacecraft will sweep the skies for up to 28 months using state-of-the-art ultraviolet detectors. Looking in the ultraviolet will single out galaxies dominated by young, hot, short-lived stars that give off a great deal of energy at that wavelength. These galaxies are actively creating stars, therefore providing a window into the history and causes of galactic star formation.

"The Galaxy Evolution Explorer is crucial to understanding how galaxies, the basic structures of our universe, form and function," said Dr. Anne Kinney, director of astronomy and physics in the Office of Space Science at NASA Headquarters, Washington. "Its ultraviolet observations will round out the knowledge we gain from observations in infrared and other wavelengths."

Astronomers believe the universe originated approximately 13.7 billion years ago in a cataclysmic event called the Big Bang. Galaxies, the basic building blocks of the universe, began to appear as the fireball of hydrogen and helium gas expanded and cooled. Recent observations suggest star formation peaked some eight to 10 billion years ago. This mission is specifically designed to investigate whether this occurred and why.

The centerpiece of the satellite is a 50-centimeter-diameter (19.7-inch) telescope equipped with sensors that will gather continuous images of galaxies in the ultraviolet to study their shape, brightness and size. Ultraviolet light -- the type of invisible energy responsible for sunburn -- is at the higher end of the electromagnetic spectrum, just above visible light in frequency, but below X-rays and gamma rays.

A device called a spectrometer will break down the light into its component colors, just as a prism separates white light into a rainbow. These measurements will enable scientists to determine the distances of galaxies, and thus, their places in cosmic history. Combined with precise measurements of the ultraviolet brightness of galaxies, astronomers will be able to determine the rate at which stars are forming within those galaxies.

"This mission will provide the first comprehensive map of a universe of galaxies under construction and bring us closer to understanding how they, and our own Milky Way, were built," said Dr. Christopher Martin, the mission's principal investigator and an astrophysics professor at the California Institute of Technology in Pasadena.

Scientists will use data from the mission to learn when carbon, oxygen and other chemical elements were created inside blazing stars. Most of the elements found in the human body originated in stars. We are literally made of stardust. The mission will also conduct the first ultraviolet surveys of the entire sky beyond our own galaxy, including the first wide-area spectroscopic surveys. Rich in objects from galaxies to quasars to white dwarf stars, this vast data archive will serve as a resource for the entire astronomical community.

The Galaxy Evolution Explorer mission is led by the California Institute of Technology, which is also responsible for science operations and data analysis. NASA's Jet Propulsion Laboratory, Pasadena, Calif., a division of Caltech, manages the mission and built the science instrument. Orbital Sciences Corp., Germantown, Md., is responsible for the spacecraft, integration and testing, ground data system and mission operations, and the launch vehicle. Other partners include the University of California, Berkeley; and Johns Hopkins University, Baltimore, Md., and its Space Telescope Science Institute. The mission was developed under NASA's Explorers program, managed by the Goddard Space Flight Center, Greenbelt, Md. Key flight optics components were developed and contributed by France's Laboratoire d'Astrophysique de Marseille. Important test equipment and science operations software was developed and contributed by Yonsei University in Seoul, South Korea.

More information about the mission is available on the project web site at:

<http://www.galex.caltech.edu>

Information on NASA's Explorers Program is available at:

<http://explorers.gsfc.nasa.gov>

The launch will be broadcast live on NASA Television on the GE-2 satellite, transponder 9C, located at 85 degrees west longitude, vertical polarization, frequency 3880.0 megahertz, audio 6.8 megahertz. The launch will be carried on a live webcast at:

<http://www.jpl.nasa.gov/webcast/galexlaunch.html>

- end -

Media Services Information

NASA Television Transmission

NASA Television is broadcast on satellite GE-2, transponder 9C, C band, 85 degrees west longitude, frequency 3880.0 MHz, vertical polarization, audio monaural at 6.8 MHz. The tentative schedule for television transmissions of mission activities is described below; updates will be available from the Jet Propulsion Laboratory, Pasadena, Calif.; the Goddard Space Flight Center, Greenbelt, Md.; and NASA Headquarters, Washington.

Briefings and Television Feed

Pre-launch mission and science briefings will air on NASA Television at 1 p.m. EDT April 25, 2003. The news conference will originate from NASA Kennedy Space Center, Fla.

NASA plans to broadcast the launch live on NASA Television. The broadcast will be accessible via webcast at <http://www.jpl.nasa.gov/webcast/galexlaunch.html> .

Status Reports

NASA will issue status reports on mission activities. They may be accessed online as noted below.

Launch Media Credentialing

News media representatives who wish to cover the launch in person must be accredited through the NASA Kennedy Space Center newsroom. Journalists may contact the newsroom at 321/867-2468 for more information.

Internet Information

Information on the mission, including an electronic copy of this press kit, press releases, fact sheets, status reports and images, is available from a variety of sources. The Galaxy Evolution Explorer web site is operated by Caltech at <http://www.srl.caltech.edu/galex/> . Information is also available on the Jet Propulsion Laboratory home page at <http://www.jpl.nasa.gov> , the Goddard Space Flight Center home page at <http://www.gsfc.nasa.gov> , and the NASA Explorers Program web page at <http://explorers.gsfc.nasa.gov> .

Quick Facts

Spacecraft

Size: 1 meter (3 feet) wide, 2.5 meters (6.4 feet) high

Mass: 277 kilograms (609 pounds)

Power: 290 watts from two solar wings totaling 3 square meters (32 square feet)

Batteries: 15-amp-hour nickel-hydrogen battery providing up to 250 watts at 28 volts

Science instrument: 50-centimeter-diameter (19.7-inch) telescope with two ultraviolet detectors (near- and far-ultraviolet)

Launch Vehicle

Type: Pegasus XL

Length: 16.9 meters (55.6 feet)

Diameter: 1.3 meters (4.2 feet)

Weight: 23,130 kilograms (50,900 pounds)

Stages: Three

Fuel: Solid

Mission

Launch: No earlier than April 28, 2003 from Kennedy Space Center, Florida

Primary mission: One year plus 1-month in-orbit checkout, with possible extension to 28 months

Orbit altitude: 690 kilometers (about 429 miles)

Orbit inclination to Earth's equator: 29 degrees

Orbital period: 96 minutes

Mission Overview

The Galaxy Evolution Explorer is an orbiting telescope that will observe a million galaxies across 10 billion years of cosmic history using state-of-the-art ultraviolet detectors. The satellite will be launched into a circular orbit around Earth at an altitude nearly twice that of the International Space Station. After one month of in-orbit checkout, the telescope will spend at least one year, but up to 28 months conducting its scientific mission of exploring galaxies in the ultraviolet.

Launch Site and Vehicle

The spacecraft will be launched from Cape Canaveral, Fla., on a Pegasus XL launch vehicle manufactured by Orbital Sciences Corp. The three-stage Pegasus is carried aloft strapped to the body of an L-1011 jet aircraft. After the L-1011 releases the Pegasus, the rocket fires and carries its scientific payload into Earth orbit.

The Pegasus's first stage is 10.3 meters (33.7 feet) long and 1.3 meter (4.2 feet) in diameter, with an engine thrust of 726,000 newtons (163,000 pounds). The second stage is 1.3 meter (4.2 feet) long and 1.3 meter (4.2 feet) in diameter, with an engine thrust of 196,000 newtons (44,000 pounds). The third stage is 1.3 meters (4.4 feet) long and 0.97 meter (3.2 feet) in diameter, with an engine thrust of 36,000 newtons (8,000 pounds). Overall, the Pegasus rocket is 16.9 meters (55.6 feet) long, 1.3 meter (4.2 feet) in diameter, has a wingspan of 6.7 meters (22 feet), and weighs 23,130 kilograms (50,900 pounds). All three stages burn solid propellant.

Launch Timing

Launch is scheduled for 7:00 a.m. no earlier than April 28, 2003. A two-hour launch window is designed to optimize lighting conditions when the Galaxy Evolution Explorer separates from the Pegasus vehicle. This allows the satellite's batteries to regain full charge capacity with the solar arrays in the stowed position soon after separation.

Unlike planetary spacecraft, which must be launched during fixed windows of time in certain years and months in order to reach a particular planet, the Galaxy Evolution Explorer may be launched on any subsequent day if launch does not take place on the first scheduled launch day.

Launch and Ascent Phase

The L-1011 carrier aircraft, with the Pegasus launch vehicle and the Galaxy Evolution Explorer strapped to its belly, will take off northeast from a runway at Cape Canaveral Air Station and climb to an altitude of 11,900 meters (about 39,000 feet). About 160 kilometers (100 miles) off the coast of Florida the carrier aircraft will release the Pegasus rocket, which will drop for about 5 seconds, then ignite its first-stage motor.

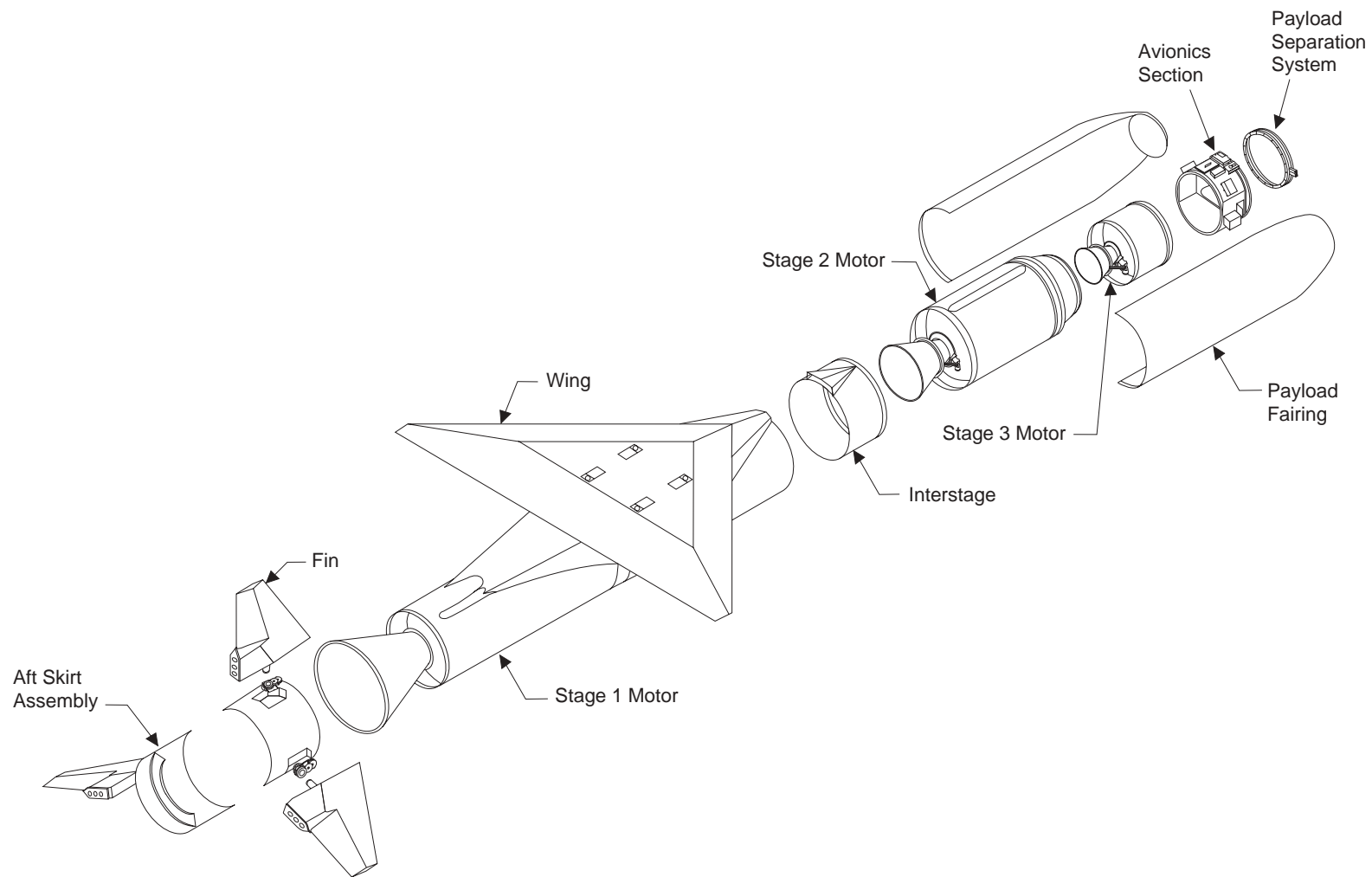

Pegasus XL launch vehicle

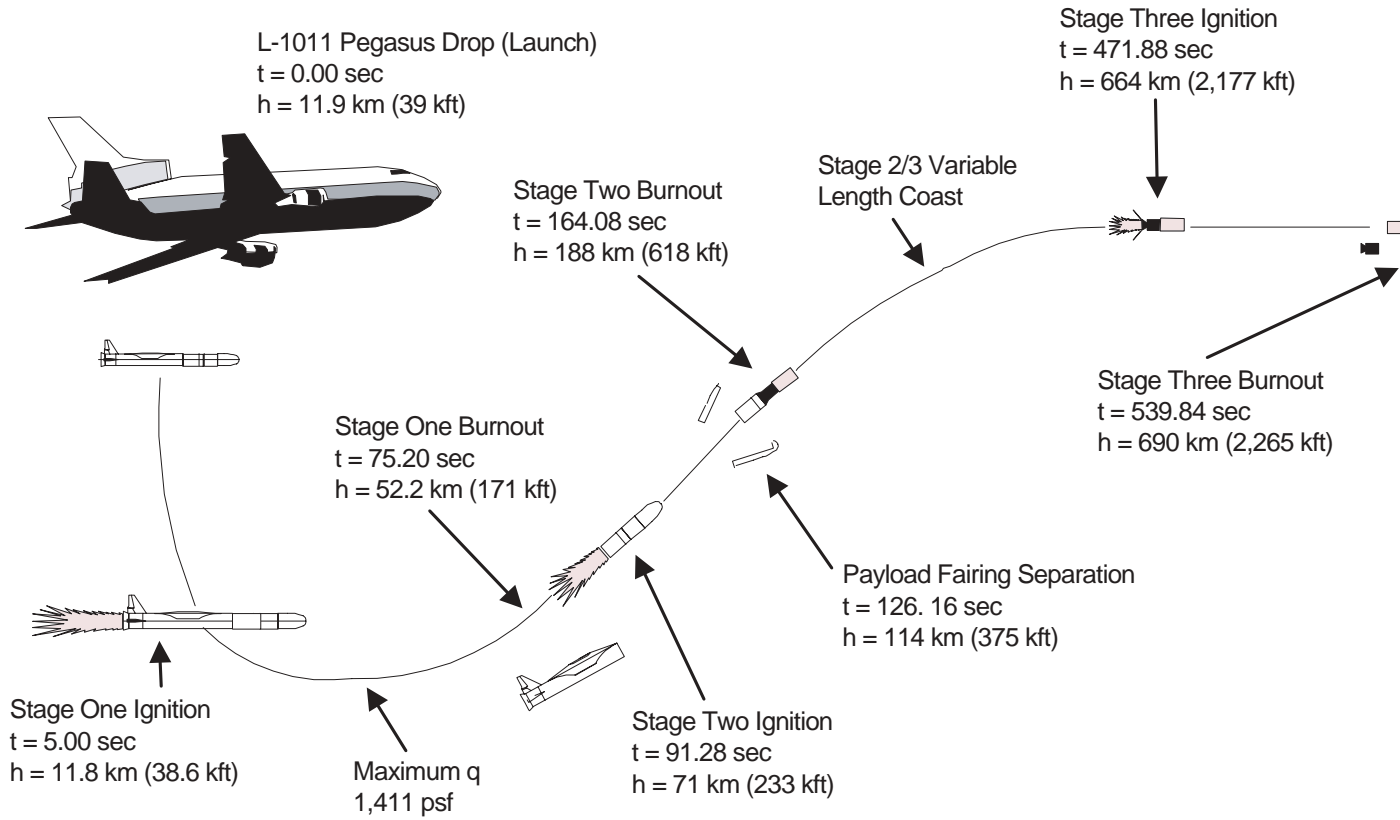

Launch phases

After the first stage burns for 70 seconds it will drop away and the second stage will ignite, burning for about a minute and a half. While the second stage is burning, pyrotechnic devices will be fired to release the nose cone, or fairing.

When the second stage burns out, the rocket and spacecraft will coast for about five minutes. The third stage will then ignite as it approaches the west coast of Africa and fire for 68 seconds.

Ten minutes after the initial release from the L-1011 aircraft, the Galaxy Evolution Explorer will separate from the Pegasus rocket's third stage. It will then be in its final orbit 690 kilometers (about 429 miles), circling the planet once every 96 minutes. The orbit is inclined 29 degrees to Earth's equator.

Three seconds after the satellite separates from the launch vehicle, the Pegasus' third stage will execute a 90-degree turn, pause for five minutes, then execute a second 90-degree turn in a collision avoidance maneuver. The third stage will fire its small thrusters until its propellant gas is depleted, slowing it slightly; eventually it will reenter Earth's atmosphere and burn up.

Acquisition and Deploy Phase

When Galaxy Evolution Explorer separates from the Pegasus, the satellite's system that controls its orientation in space, or "attitude," will begin to stabilize it. Around this time, the first signal from the spacecraft will be received on the ground, most likely by a station near Perth, Australia. The satellite will deploy its solar arrays, and its sensors will lock on to the Sun.

In-Orbit Checkout and Calibration

The first three days after launch are dedicated to checkout of spacecraft components and its interface to the science instrument. The first two weeks after launch are considered a decontamination period when moisture and other materials absorbed into the satellite's paints and thermal blankets bleed away, or "outgas." On day 8, the telescope's cover will be deployed. On day 15, high-voltage electrical power to the science detectors will be turned on. The remainder of the first month will be devoted to calibrating the instrument and making the first scientific observations.

Science Mission

After the first shakeout month, the science mission begins. The first 20 months of the potential 28-month science mission are dedicated to conducting eight specific surveys. Those surveys will also continue during the final eight months of the mission, but they will be augmented by other observations designed by associate investigators on the mission.

All science observations will be made during the portions of the orbit when the satellite passes into Earth's shadow. The spacecraft will recharge its batteries and communicate with ground stations during the sunlit portion of its orbit.

Mission Operations

Mission operations will be conducted from a center in Dulles, Va., managed by Orbital Sciences Corp. Controllers will communicate with the satellite through ground stations on the island of Hawaii and near Perth, Australia, owned by Universal Space Network Inc.

In case of contingency, a backup mission control center capability exists at Universal Space Network's network management center in Horsham, Pa. The North American Aerospace Defense Command will provide spacecraft tracking information.

During the initial in-orbit checkout phase in the first month after launch, controllers will also receive data from the satellite via NASA's Tracking and Data Relay Satellites via a ground station in White Sands, N.M.

Science Data Processing and Archiving

Data from the orbiting telescope will be processed and calibrated at the California Institute of Technology, Pasadena, Calif., which will also archive raw telemetry from the satellite. The science operations and data analysis center at Caltech will be the primary center for day-to-day science operations.

Science analysis products will be assembled into an archive based on the Sloan Digital Sky Survey Archive developed by John Hopkins University in Baltimore. The Space Telescope Science Institute is developing the archive and will host the science database as part of its multi-mission archive during and after the mission. Scientists from around the world will be able to access the mission's data from this archive.

Why Study How Galaxies Form?

It may be a rare experience for city-dwellers, but a clear, moonless night in the country offers an astonishing sight: an amazing dark-velvet blanket studded by glistening stars, across which meanders the glowing road of the Milky Way.

Modern astronomers know that when we look at the Milky Way we are in fact seeing the edge of a galaxy, a pinwheel-shaped collection of more than 100 billion stars, among them an average one that we call our own Sun about two-thirds of the way out one of the galaxy's arms. Although other galaxies were visible for centuries to even simple telescopes as fuzzy smudges of light, it wasn't until the 1920s that astronomers reached a consensus that they too were groupings of enormous numbers of stars. This was thanks in part to the American astronomer Edwin Hubble, who observed pulsating stars in a blurry patch in the constellation of Sagittarius and concluded that it was far too distant to be part of our galaxy, and must therefore be one of its own.

What We Know About Galaxies

The past few decades have also been marked by remarkable advances in our understanding of how the universe formed. Astronomers now generally agree on a model called the Big Bang, which holds that all of the matter and energy in the universe was once contained in a compressed state of unimaginably high density and temperature that abruptly expanded in an explosion-like event 13.7 billion years ago. Within a million years the young universe cooled enough for atoms to form, leaving clouds of simple atoms of hydrogen. Perhaps 1 billion to 2 billion years after the Big Bang, much of this gas condensed into swirling galaxies, and then into separate stars.

Astronomers today estimate that there are at least 10 billion galaxies in the visible universe. Most galaxies are arranged in clusters. Our own Milky Way belongs to a small cluster of about 40 galaxies, called the Local Group. The group is about 3 million light-years across, with most of its contents in two large spiral galaxies, our Milky Way and the neighboring Andromeda galaxy. Our Local Group is part of the Local Supercluster, a thin sheet of galaxy clusters. In between the various superclusters in the universe are voids, regions with few galaxies. Most of the universe consists of these voids.

Not all galaxies gather into groups or clusters, however; some appear like hermits far from neighbors. The "urban-dwelling" galaxies seem to have different properties than the loners. Some galaxies appear to form huge quantities of stars in a rapid flash of activity early in their history, while other galaxies display a slower, but gradual star formation.

Scientists have classified galaxies according to their shape, although they don't know why they form different shapes in the first place. Spiral galaxies, like our Milky Way, form stars gradually. They contain young, middle-aged and old stars, and large

amounts of gas and dust. Elliptical galaxies are football-shaped and have little visible gas and dust; they appear to contain mostly old stars that formed fast and early. Irregular galaxies, with no regular shape or motion, have bursts of star formation. Peculiar galaxies are odd in shape and form, and are usually in the process of forming stars.

Astronomers also wonder how galaxies manage to churn tenuous cosmic gases and dust to the point that the matter collapses into the dense, fiery material that makes up stars. They know that a large portion of a galaxy is made up of seemingly invisible "dark matter." They don't know what dark matter is, how it got there, and what role it plays in the evolution of galaxies.

While scientists have been trying to decipher the mysteries of galaxies, these cosmic entities have even seeped into popular culture. Movie fans may have munched on a

How Ultra is the Ultraviolet?

Light, heat, X-rays, television and radio might seem like very different things, but they are all forms of what scientists call electromagnetic radiation. Our eyes can detect only a very tiny sliver of the enormous bombardment of energy that washes over us at any instant.

All of these kinds of energy differ by frequency and wavelength. As the frequency goes up, the wavelength gets shorter. A signal picked up by an AM radio, for example, might be at a frequency of about 1 million cycles per second, or 1 megahertz, and the wavelength is 300 meters (984 feet). By contrast, the frequency of visible light is a billion times higher and the wavelength is a billion times shorter. X-rays and gamma rays are at still higher frequencies and shorter wavelengths.

The wavelength of visible light ranges from about 400 to 700 nanometers (billionths of one meter). Red light, for example, is around 650 to 700 nm, while green is about 500 to 550 nm, blue is around 450 nm and violet is roughly 400 nm. (Sometimes scientists measure the wavelength of light in a unit called an angstrom. This unit, 1/10th of a nanometer, is named for the Swedish physicist Anders Ångström.)

Infrared is called "infra" because its frequency is below that of visible light. Ultraviolet -- the target of the Galaxy Evolution Explorer mission -- is called "ultra" because its frequency is higher.

Overall the ultraviolet spectrum ranges in wavelength from about 400 nm, where violet light trails off, down to only 4 nm. The ultraviolet radiation in sunlight is divided into three bands: UVA (320-400 nm), which can cause skin damage and may cause melanomatous skin cancer; UVB (280-320 nm), stronger radiation that increases in the summer and is a common cause of sunburn and most common skin cancer; and UVC (below 280 nm), the strongest and potentially most harmful form. Much UVB and most UVC radiation is absorbed by the ozone layer of the atmosphere before it can reach Earth's surface, which is good for human health but not so good for ultraviolet astronomy. That's why the Galaxy Evolution Explorer must be lofted above the atmosphere to carry out its mission.

The mission's science concentrates on observing galaxies in two subregions of the ultraviolet spectrum. The telescope will make observations in the "near" ultraviolet at wavelengths of about 180 to 300 nm. A second detector will observe galaxies in the "far" ultraviolet at about 130 to 180 nm.

Science Objectives

The primary objective of the Galaxy Evolution Explorer is to learn what factors trigger star formation inside galaxies; how quickly stars form, evolve and die; and how heavy chemical elements form in stars.

Additional goals include:

- Determining how fast stars are forming inside each galaxy
- Determining when and how the stars we see today formed
- Creating the first map of the ultraviolet universe
- Helping scientists find and understand ultraviolet bright quasars. These objects can serve as background sources for the Hubble Space Telescope and FUSE as it probes the gases from which galaxies form stars

To accomplish its objectives, the Galaxy Evolution Explorer will conduct eight surveys, grouped into two broad categories - a local universe investigation and a star formation history investigation.

The local universe investigation includes the following four surveys:

- All-sky imaging survey** - will look at the entire sky and develop a comprehensive catalogue of ultraviolet galaxy images, useful to map the distribution of star formation within the local universe
- Nearby galaxy survey** - will study about 150 nearby galaxies that are familiar to scientists to understand how stars formed in individual galaxies
- Wide-field spectroscopic survey** - will analyze the light wavelengths of galaxies in a wide swath of the sky
- Medium spectroscopic survey** - will examine the light properties of galaxies within a narrower portion of the sky

The star formation history investigation will take information gathered by the local universe investigation and apply it to more distant galaxies by looking further back in time. It includes the following four surveys:

- Deep imaging survey** - will look at a portion of the sky to study the distribution of star formation in the deep universe
- Deep spectroscopic survey** - will look for the most distant galaxies
- Ultra-deep imaging survey** - will look as deep as possible at a very small portion of the sky
- Medium imaging survey** - will study star formation in galaxies beyond our local cosmic neighborhood, but not as deep as the deep imaging survey

Milky Way candy bar while watching Star Wars, a story that takes place a "long time ago in a galaxy far, far away."

Although astronomers have learned a great deal about galaxies since the 1920s, there are still many mysteries waiting to be solved. NASA's Galaxy Evolution Explorer is an important part of that quest.

In Search of Stellar Nurseries

The mission searches for galaxies in which young stars are forming by taking advantage of a peculiarity in the kind of energy that stars put out. A mid-sized, middle-aged star like our Sun throws off energy across a large spectrum of wavelengths, from infrared to visible light to ultraviolet. However, ultraviolet makes up less than 5 percent of the energy given off by the Sun.

Very massive stars, on the other hand, throw off an enormous amount of ultraviolet energy. Fast-trackers that live on the edge and burn the candle at both ends, these

Science Team

Co-investigator

Institution

Christopher Martin	California Institute of Technology, Pasadena, Calif.
Peter Friedman	Caltech
David Schiminovich	Caltech
Barry Madore	Caltech
Luciana Bianchi	Johns Hopkins University, Baltimore, Md.
Alex Szalay	Johns Hopkins University
Tim Heckman	Johns Hopkins University
Bruno Milliard	Laboratoire d'Astrophysique de Marseille, France
Jose Donas	Laboratoire Astronomie Spatiale
Roger Malina	Laboratoire d'Astrophysique de Marseille / University of California, Berkeley
Mike Rich	University of California, Los Angeles
Ossy Siegmund	University of California, Berkeley
Young-Wook Lee	Yonsei University, Seoul, South Korea
Yong-Ik Byun	Yonsei University
Genna Kanner	Arcadia Unified School District, Arcadia, Calif.

Associates

Todd Small	Caltech
Tom Barlow	Caltech
Karl Forster	Caltech
Marie Treyer	Laboratoire d'Astrophysique de Marseille
Patrick Morrissey	Caltech
Ryan McClean	Caltech

stars shine brightly and die early. Since they never get to be middle-aged like our Sun, any galaxy with a lot of these ultraviolet-bright stars must be one in which new stars are vigorously forming.

The telescope on the Galaxy Evolution Explorer thus peers out into the universe at ultraviolet wavelengths to look for these stellar nurseries. As it conducts its sky surveys, the telescope will observe millions of galaxies. Why so many?

Let's say an alien from some other planet wanted to learn how people on Earth age, but didn't want to spend 75 years watching a group of babies grow up and grow old. Instead, the alien could study 100 one-year-old babies, 100 two-year-olds, 100 50-year-olds, 100 75-year-olds, etc. The alien would not be able to write a specific biography of any one person, but it would learn an awful lot about the life of an "average" human. It would learn at what ages children grow fastest, how much time people spend eating and sleeping, and other characteristics that would help the alien describe the life of an average human. In the same way, the Galaxy Evolution Explorer will study many galaxies to learn about the life of an average one.

The telescope will examine galaxies both near and far. The farther we look out into space, the farther back in time we are seeing. The most distant galaxies that the Galaxy Evolution Explorer will see are about 10 billion light-years from Earth. Since the universe is thought to be 13.7 billion old, the mission will catalog galaxies across 80 percent of the history of the universe.

The mission will enable scientists to reconstruct the history of our Milky Way galaxy by studying similar galaxies. It will help answer questions about how the Milky Way began and how our star, the Sun, formed within it, an event that paved the way for the eventual development of our solar system, Earth and life.

Another topic of study for the mission is the history of how heavy elements formed in the universe. The original atoms created relatively soon after the Big Bang were simple ones of hydrogen and helium, each containing just one or two pairs of protons and electrons. "Heavy" elements, on the other hand, are the other hundred or so elements on the periodic tables that hang on the walls of science classrooms across the country -- in other words, any element that's heavier than hydrogen and helium. All of these other elements formed as part of nuclear fusion deep inside stars that later died. Elements that make up our bodies, such as carbon and oxygen, were all created in the forge of long-dead stars. We are literally made of stardust.

By using the mission to study other galaxies, scientists will determine which elements formed at various points in cosmic time. They will then apply this information to our Milky Way galaxy to pinpoint which elements existed when our solar system formed.

Blazing New Trails in Astronomy

The mission will provide the first-ever wide-area ultraviolet surveys of the sky, and the first wide-area spectroscopic surveys. Not only will it help us understand the cosmic events that shaped the history of our universe, but through its discoveries, the Galaxy Evolution Explorer will help design the future of astronomy.

The Hubble Space Telescope was named after the man who first discovered galaxies. The telescope that bears his name has imaged numerous galaxies, both individually and in such elegant groupings as the Hubble deep-field images, which show a tiny portion of the sky peppered with galaxies. The Galaxy Evolution Explorer, by observing large pieces of the sky all at once, will find the most rare and interesting objects in the universe. These objects may become the target of future observations by the Hubble Space Telescope.

When massive stars emit ultraviolet light, much of it is absorbed by dust. The dust then emits heat in infrared wavelengths, which, like ultraviolet, are not visible to the naked eye. The ultraviolet observations of the Galaxy Evolution Explorer will work hand in hand with those of future infrared missions, such as NASA's Space Infrared Telescope Facility, scheduled for launch in 2003, and the James Webb Space Telescope, planned for later this decade. Both of those infrared missions will observe some of the galaxies studied in ultraviolet light by the Galaxy Evolution Explorer. This will give a more complete picture of each galaxy. The mission's legacy will also benefit ground-based observations.

In addition to studying galaxies, the mission will compile a substantial archive of other objects of interest to astronomers. These include active galactic nuclei, often associated with massive black holes at the centers of galaxies; white dwarfs, old stars that have blown off their outer shells, leaving very hot cores that are bright in the ultraviolet; and quasars, thought to be associated with black holes and galactic nuclei.

Spacecraft

The Galaxy Evolution Explorer would fit on a tabletop. It is a cylinder measuring about 1 meter (3 feet) in diameter and 2.5 meters (6.4 feet) high, weighing 277 kilograms (609 pounds). Its structure is composed primarily of aluminum.

The basic satellite design is new, but shares elements in common with several satellites now under development by Orbital Sciences Corp. Much of the flight software is derived from software developed for NASA's Far Ultraviolet Spectroscopic Explorer and for Orbview 4, a commercial imaging satellite.

Command and Data Handling

All of the satellite's computing functions are performed by the command and data handling subsystem. The heart of this subsystem is a Rad 6000 computer, a radiation-hardened version of the PowerPC chip used on some models of Macintosh computers. The chip is also used on many other spacecraft such as the Mars Pathfinder lander. With 128 megabytes of random access memory and three megabytes of non-volatile memory, which allows the system to maintain data even without power, the computer runs Galaxy Evolution Explorer's flight software and controls various other parts of the satellite.

Among tasks managed by the computer are Sun avoidance; deployment of the solar arrays; precision determination and control of the satellite's orientation (or "attitude"); thermal management; automated fault detection and correction; communication with the telescope instrument; and acquisition, storage and transmission of science data.

A 24-gigabit solid-state recorder stores engineering data from the satellite and science instrument, and science data from the instrument.

An uplink card operates independently of the onboard computer and is responsible for receiving, validating and decoding commands from the ground. Commands are routed to three paths for execution: special commands, normal command traffic and stored commands. Special commands operate independently of the onboard computer, thereby bypassing the processing associated with normal command traffic. Special commands are typically used for reconfiguration and/or hard resets for the command and data handling subsystem. They can also be used to place the satellite in a "safe" mode, if this is commanded from the ground.

A downlink card is responsible for receiving telemetry data received from various spacecraft subsystems, the science instrument and the solid-state recorder, and preparing them for transmission to ground stations.

Electrical Power

This subsystem is responsible for generating, storing and distributing the satellite's electrical power. It is designed to provide substantial power margins using a minimal solar array area.

Power is generated by 2.9 square meters (31.2 square feet) of gallium arsenide solar cells mounted on two fixed wings. Total area of the arrays is 3 square meters (32.2 square feet).

Power is stored in a 15-amp-hour nickel-hydrogen battery. The battery can support spacecraft power needs for the 36 minutes of each orbit during which the Sun is eclipsed from the satellite.

The power electronics suite consists of three boxes: the battery sensor electronics, the power module, and the power and thermal control electronics. The battery sensor electronics box conditions battery temperature and pressure, and controls battery heaters. The power module converts the voltage from the solar arrays to levels required by various devices on the spacecraft. The power and thermal control electronics box provides overall control of the power subsystem.

Thermal Control

This subsystem maintains proper temperature of equipment on the satellite. It uses passive components, such as radiators, blankets and thermal paints, as well as redundant heaters controlled by flight software. Mechanical thermostats control survival heaters in the event that the satellite enters a safhold condition.

To control battery temperature, the battery cells are connected to a dedicated radiator by heat-conducting sleeves. A thermal blanket is used to protect the cells from the space environment.

Attitude Determination and Control

The Galaxy Evolution Explorer is a "three-axis-stabilized" spacecraft, meaning that it can be held in any orientation in relation to space. The system is fully autonomous, meaning that it relies on onboard systems to control the satellite orientation, or "attitude," with no intervention required from ground controllers.

Unlike some spacecraft, the Galaxy Evolution Explorer has no thrusters to adjust its orientation. Instead, it achieves this with four devices called reaction wheels, which use the momentum of spinning wheels to nudge the satellite in one direction or another. Occasionally the reaction wheels accumulate too much momentum, which requires the use of devices called torque bars -- somewhat like large electromagnets -- to push against Earth's magnetic field and cancel out some of the momentum in the wheels.

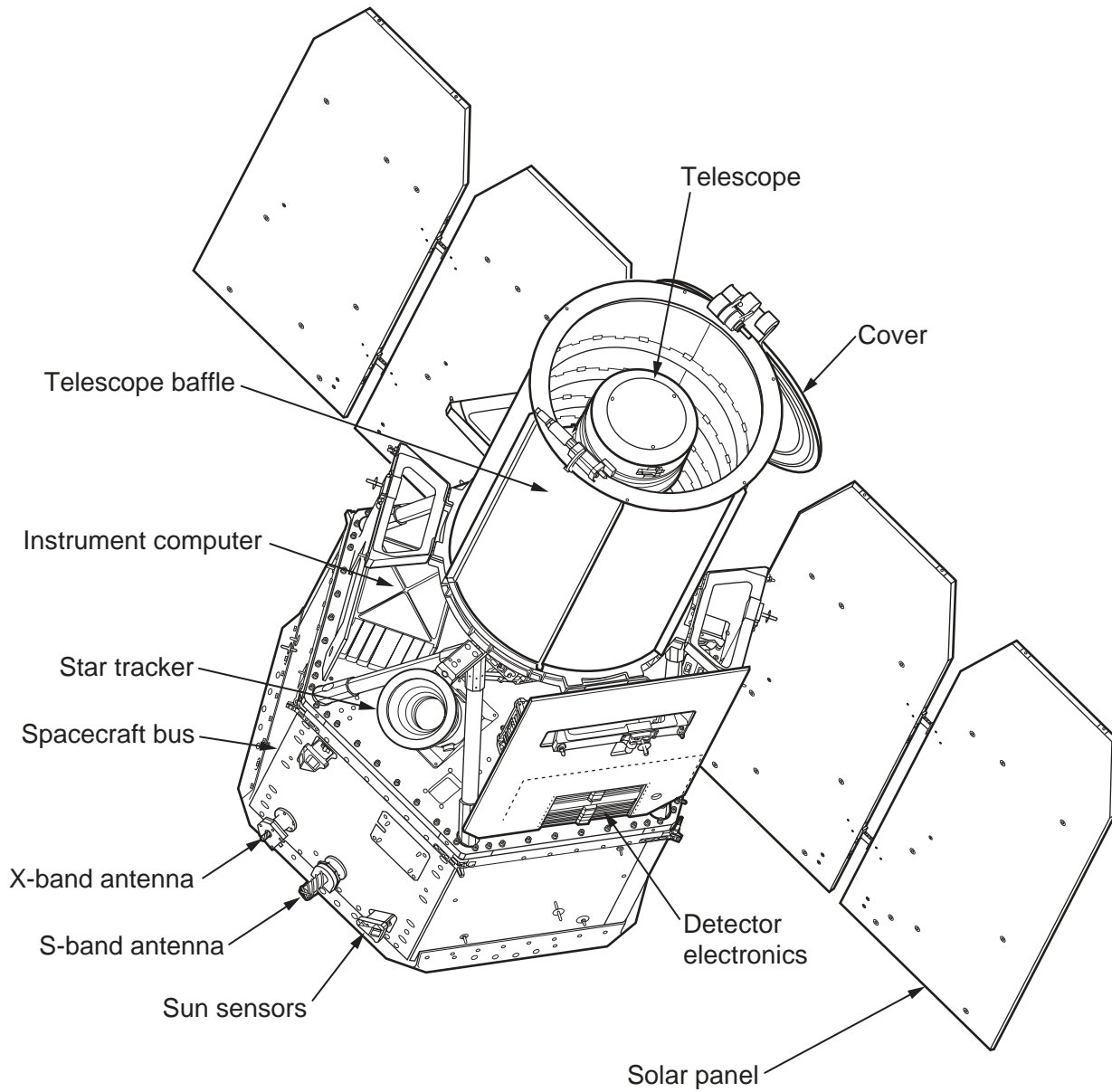

Spacecraft exterior

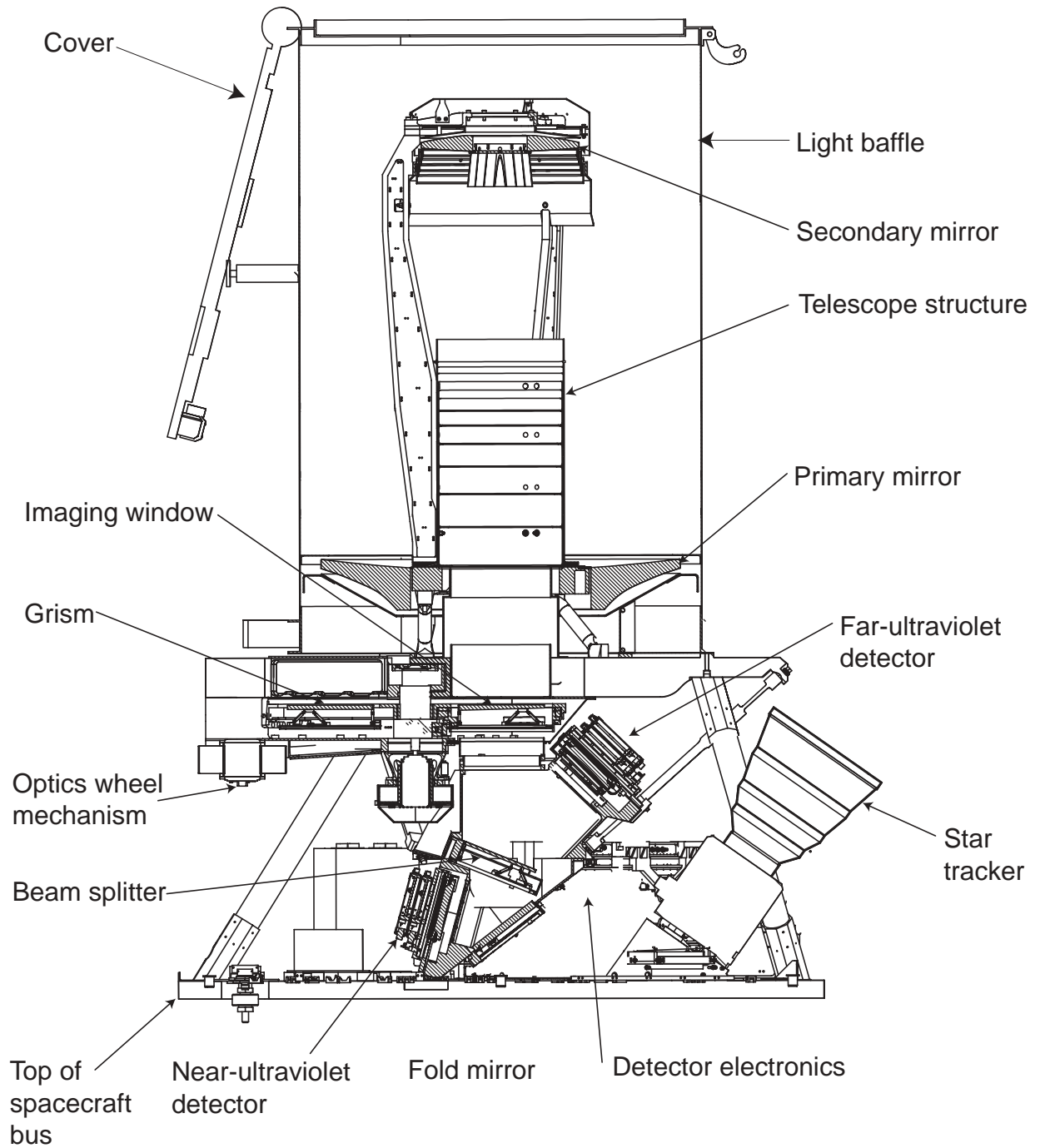

Spacecraft cutaway

The torque bars are controlled by a device called a magnetometer that senses the orientation of Earth's magnetic field.

The satellite's orientation is sensed by a star tracker, while its rotation rates are sensed by gyroscopes. The star tracker is also used to correct slow drifts that occur in the gyroscopes' sensing circuits. Two Sun sensors provide a relatively coarse measure of the Sun's direction when the satellite is in safehold modes.

Telecommunications

The radio system operates in both the S-band and the X-band ranges of the microwave spectrum. The S-band transmitter sends basic spacecraft data, or "telemetry," to Earth, while two S-band receivers accept commands from the ground. The 5-watt S-band transmitter sends data at 2 megabits per second, and the receivers operate at 2,000 bits per second. The X-band transmitter, which sends science data, transmits at 24 megabits per second with an output power of 6 watts.

The Telescope

At the heart of the Galaxy Evolution Explorer is a telescope designed to look out into space from Earth orbit. In certain ways the telescope is like a smaller version of the Hubble Space Telescope. It is quite a bit smaller than Hubble, however, and it has fewer instruments to record the light gathered by its main mirror. In addition, it is optimized for one specialty -- surveying galaxies in ultraviolet light.

Like Hubble, the telescope is of a Cassegrain design, named for the French sculptor Guillaume Cassegrain, who invented it in 1672. In this design, light from distant objects in space enters the telescope and is reflected by a primary mirror at the telescope's rear. The light

is then gathered onto a smaller mirror suspended in the middle of the telescope near the front end. The light in turn reflects back toward the rear of the telescope, where it passes

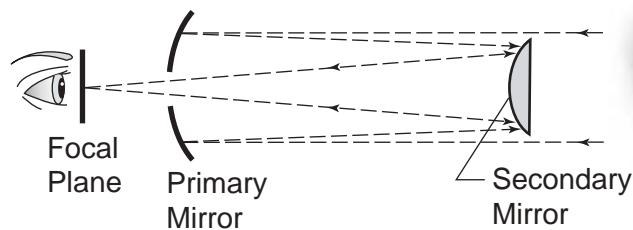

Cassegrain telescope design

through a hole in the middle of the primary mirror. At the rear, behind the primary mirror, is the sensor that records the image. Three centuries ago, this "sensor" would have been the eye of the astronomer peering into the telescope. Later, the living eye was replaced by photographic film. Modern space telescopes record images with electronic devices which turn them into digital data that can be transmitted to Earth.

The primary mirror in the Galaxy Evolution Explorer's telescope is 50 centimeters (19.7 inches) in diameter. Like mirrors in many amateur telescopes, it is made of a kind of glass called fused silica, with a thin coating of aluminum. The aluminum must be protected by another coating of a clear material, however, to keep it from oxidizing and degrading. The coatings used in conventional telescopes would not work for this mission because they absorb too much of the ultraviolet light that the instrument is designed to gather. The optics in the telescope are therefore coated with a material called magnesium fluoride, which is transparent to ultraviolet light.

Scientists want to hunt for star birthing galaxies, in both the near-ultraviolet and the far-ultraviolet, so the telescope must deliver the light it gathers to two separate detectors. It accomplishes this in an ingenious way. Instead of swapping out different detectors at different times, the telescope directs the light through an unusually shaped lens that scientists call a "dichroic beam-splitter." This lens is coated with many extremely thin layers of special materials that cause the far-ultraviolet light to reflect off the lens surface, while allowing the near-ultraviolet light to proceed unimpeded through the lens. The reflected light proceeds to the far-ultraviolet detector, while the light that passes

through the lens proceeds to the near-ultraviolet detector. This allows both detectors to perform science observations at the same time.

Compared to most telescopes either on the ground or in space, the Galaxy Evolution Explorer's instrument has a very wide field of view -- about 1-1/4 degree, or nearly three times the diameter of the Moon. With a field of view this large, objects around the edges of the visible area become distorted. The beam-splitter's unusual shape corrects this distortion.

After going their separate ways at the beam-splitter, near-ultraviolet and far-ultraviolet light are each filtered one more time to remove unwanted wavelengths. The detector for near-ultraviolet light is also sensitive to visible light, which must be removed. This is accomplished by reflecting the light off a mirror with a sophisticated coating that cuts out visible light but reflects the near-ultraviolet.

The far-ultraviolet light is passed through a filter that cuts off very short wavelength light resulting from the ultraviolet glow produced by Earth's tenuous upper atmosphere. This glow would otherwise ruin the instrument's view of distant galaxies.

Eventually the light, both near- and far-ultraviolet, reaches its ultimate destination, the pair of detectors. These are devices somewhat similar to detectors in night vision goggles in the sense that they can react to very low levels of light, but they are optimized for ultraviolet rather than visible light. The detectors are contained in sealed tubes and are the largest detectors of their kind ever flown in space.

In addition to gathering basic ultraviolet images, scientists are also interested in analyzing the spectral signatures of light from distant galaxies to measure their "red shift." Because of the Big Bang, all of the galaxies in the universe are moving away from each other. Like dots taped to an expanding balloon, galaxies that are farther apart move away faster from each other.

The light from a galaxy moving away from us is shifted to the red end of the spectrum. The farther from us it is, the greater the "red shift." Scientists use this red shift to determine the galaxy's distance. Because these distances are enormous, the light from distant galaxies takes a significant fraction of the age of the universe to reach us. Scientists thus can view galaxies of any age, back to the time when they first formed.

The Galaxy Evolution Explorer's instrument is therefore equipped with a "grism" lens mounted so that it can be rotated into the beam of light coming from the telescope. The grism gets its name from the fact that it is a prism with a grating on one surface. This lens breaks down light into its various color wavelengths, which reveal telltale lines caused when light is absorbed or emitted by various elements. The grism on the Galaxy Evolution Explorer is made from calcium fluoride crystal, the first such optic to be flown in space.

The telescope is shielded by a cover that is opened shortly after launch. Once opened

the cover cannot be closed, so spacecraft controllers must exercise caution never to let the telescope point too close to the Sun or the bright Earth. In addition, the satellite itself automatically prevents the telescope from being pointed too near to the Sun.

Cleanliness is always important in building spacecraft, but it was especially so in the case of assembling the instrument for the Galaxy Evolution Explorer. Organic contamination only two molecules thick would be devastating to the ultraviolet performance of the optics. Elaborate measures are therefore taken to assure that all materials, processes and environments that the instrument is exposed to are carefully controlled.

NASA's Explorer Program

The Galaxy Evolution Explorer mission was developed under NASA's Explorers Program, managed by the Goddard Space Flight Center in Greenbelt, Md. Created in 1990, the program sponsors competitively selected small and medium-sized missions in astrophysics and space physics.

Missions developed under the program are relatively moderate in cost and are built, tested and launched on short time schedules. They are designed to explore questions in such areas as the study of stars and galaxies, the structure and evolution of the universe, and the physics of our own Sun.

Explorer satellites have made impressive discoveries. Among them are findings related to Earth's magnetosphere and gravity field, the solar wind, micrometeoroids, the physics of Earth's atmosphere and ionosphere, solar plasma, energetic particles, and radio and gamma ray astronomy, among many others.

The program's missions are divided into several classes, according to their scope and budget. Small Explorer missions have budgets (including development, launch, mission operation and data analysis) not to exceed \$75 million. Medium-class Explorer missions are not to exceed \$180 million in total costs. University-class Explorers are budgeted within a \$15 million cost range. Another category of projects, called missions of opportunity, are not to exceed \$35 million. Competitively selected, missions are lead by a single principal investigator from the government, university or industry communities. The principal investigator is responsible for scientific and programmatic success.

Operating Explorer Missions

Mission name, launch date

Solar Anomalous and Magnetospheric Particle Explorer: July 3, 1992

Fast Auroral Snapshot Explorer: August 21, 1996

Advanced Composition Explorer: August 25, 1997

Transition Region and Coronal Explorer: April 1, 1998

Submillimeter Wave Astronomy Satellite: December 5, 1998

Far Ultraviolet Spectroscopic Explorer: June 24, 1999

Imager for Magnetopause-to-Aurora Global Exploration: March 25, 2000

High Energy Transient Explorer 2: October 9, 2000

Microwave Anisotropy Probe: June 30, 2001

Ramaty High Energy Solar Spectroscopic Imager: February 5, 2002

Explorer Missions in Development

Mission name, launch date

Cosmic Hot Interstellar Plasma Spectrometer: December 2002

Two Wide Angle Imaging Neutral-Atom Spectrometers: Late 2003 and early 2005

Swift: December 2003

Coupled Ion-Neutral Dynamics Investigations: October 2003

Astro-E2: February 2005

Program/Project Management

NASA's Jet Propulsion Laboratory, Pasadena, Calif., is the implementing center for the Galaxy Evolution Explorer, and provides project management, mission assurance and other support services, and developed, integrated and tested the science instrument. The mission is led by the California Institute of Technology, home institution of the principal investigator. Caltech is also responsible for science operations and data analysis.

At NASA Headquarters, Edward Weiler is associate administrator for space science. George Albright is the Galaxy Evolution Explorer program executive, and Philippe Crane is the program scientist.

At Caltech, the principal investigator is Christopher Martin, the project scientist is Peter Friedman, and the science operations and data analysis manager and instrument scientist is David Schiminovich. The JPL project manager is James Fanson.

The mission was developed under NASA's Explorers Program, managed by the Goddard Space Flight Center, Greenbelt, Md. The Explorers Program office at Goddard is managed by Anthony B. Comberiate, and Frank Snow is the manager responsible for the Galaxy Evolution Explorer. Susan Neff is the Goddard mission scientist.